

Curve di carico – Courbes de charges – Load diagrams – LastKurven – Curvas de cargas

	<table border="1"> <tr><td>3</td><td>25</td><td>29</td><td>m</td></tr> <tr><td>800</td><td>800</td><td>800</td><td>kg</td></tr> </table>	3	25	29	m	800	800	800	kg	OP	<table border="1"> <tr><td>3</td><td>25</td><td>29</td><td>m</td></tr> <tr><td>1000</td><td>1000</td><td>1000</td><td>kg</td></tr> </table>	3	25	29	m	1000	1000	1000	kg					
3	25	29	m																					
800	800	800	kg																					
3	25	29	m																					
1000	1000	1000	kg																					
	<table border="1"> <tr><td>3</td><td>10.3</td><td>12</td><td>16</td><td>20</td><td>24</td><td>28</td><td>31</td><td>m</td></tr> <tr><td>4000</td><td>4000</td><td>3290</td><td>2290</td><td>1735</td><td>1380</td><td>1135</td><td>1000</td><td>kg</td></tr> </table>	3	10.3	12	16	20	24	28	31	m	4000	4000	3290	2290	1735	1380	1135	1000	kg					
3	10.3	12	16	20	24	28	31	m																
4000	4000	3290	2290	1735	1380	1135	1000	kg																
	<table border="1"> <tr><td>3</td><td></td><td>18.5</td><td>20</td><td>24</td><td>28</td><td>31</td><td>m</td></tr> <tr><td>2000</td><td></td><td>2000</td><td>1865</td><td>1500</td><td>1240</td><td>1100</td><td>kg</td></tr> </table>	3		18.5	20	24	28	31	m	2000		2000	1865	1500	1240	1100	kg							
	3		18.5	20	24	28	31	m																
2000		2000	1865	1500	1240	1100	kg																	
<table border="1"> <tr><td>3</td><td>15.5</td><td>16</td><td>20</td><td>24</td><td>28</td><td>31</td><td>m</td></tr> <tr><td>2500</td><td>2500</td><td>2445</td><td>1865</td><td>1500</td><td>1240</td><td>1100</td><td>kg</td></tr> </table>	3	15.5	16	20	24	28	31	m	2500	2500	2445	1865	1500	1240	1100	kg								
3	15.5	16	20	24	28	31	m																	
2500	2500	2445	1865	1500	1240	1100	kg																	
	<table border="1"> <tr><td>3</td><td>11.3</td><td>14.4</td><td>m</td></tr> <tr><td>4000</td><td>4000</td><td>3000</td><td>kg</td></tr> </table>	3	11.3	14.4	m	4000	4000	3000	kg		<table border="1"> <tr><td>3</td><td>14.4</td><td>m</td></tr> <tr><td>2000</td><td>2000</td><td>kg</td></tr> </table>	3	14.4	m	2000	2000	kg	<table border="1"> <tr><td>3</td><td>14.4</td><td>m</td></tr> <tr><td>2500</td><td>2500</td><td>kg</td></tr> </table>	3	14.4	m	2500	2500	kg
	3	11.3	14.4	m																				
4000	4000	3000	kg																					
3	14.4	m																						
2000	2000	kg																						
3	14.4	m																						
2500	2500	kg																						

Reazioni – Reactions – Réactions – Eckdrücke – Reacciones

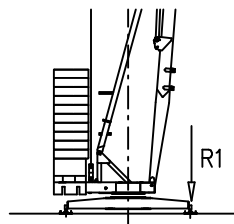

R1 ● 22 t ■ 15 t

▲ 12.7 t ○ 25.6 t

- | | | |
|-------------------------------|---------------------------------------|--------------------------------------|
| ● Reazioni in servizio | ● Reactions in service | ● Réactions en service |
| ■ Reazioni fuori servizio | ■ Reactions out of service | ■ Réactions hors service |
| ▲ Peso della gru senza assali | ▲ Dead weight without transport axles | ▲ Poids de construction sans essieux |
| ○ Peso zavorra rotante | ○ Ballast weight | ○ Poids du lest |
-
- | | | |
|--|--|---|
| ● Reaktionskräfte in betrieb | ● Reacciones en servicio | ● Em serviço |
| ■ Reaktionskräfte außer betrieb | ■ Reacciones fuera de servicio | ■ Fora de serviço |
| ▲ Konstruktionsgewicht ohne transportachse | ▲ Peso de la grua sin tren de transporte | ▲ Peso de la grua sem carro de transporte |
| ○ Ballastgewicht | ○ Peso de lastre | ○ Peso de lastre rotativo |

Montaggio – Montage – Erection – Montage – Montaje

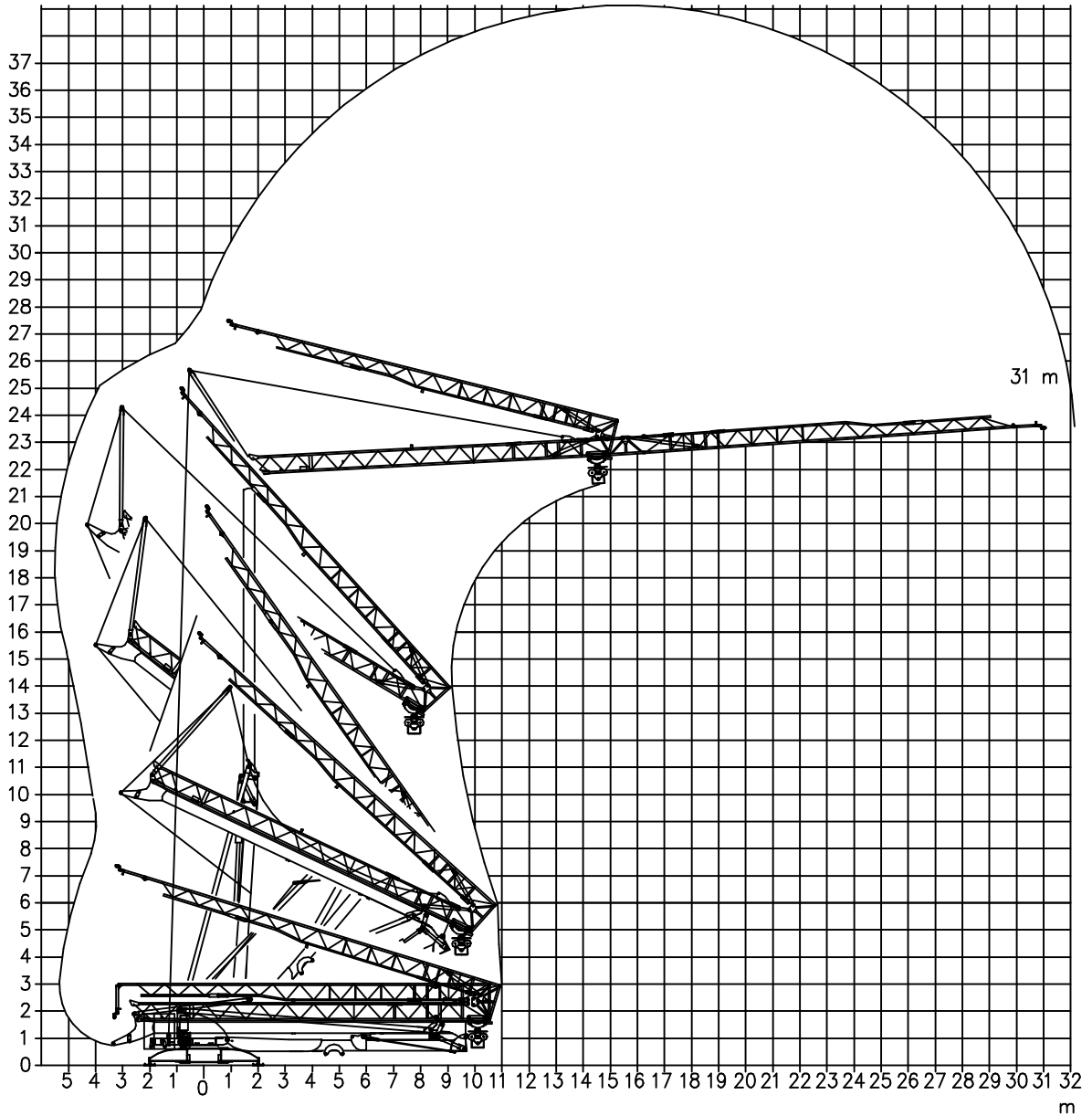



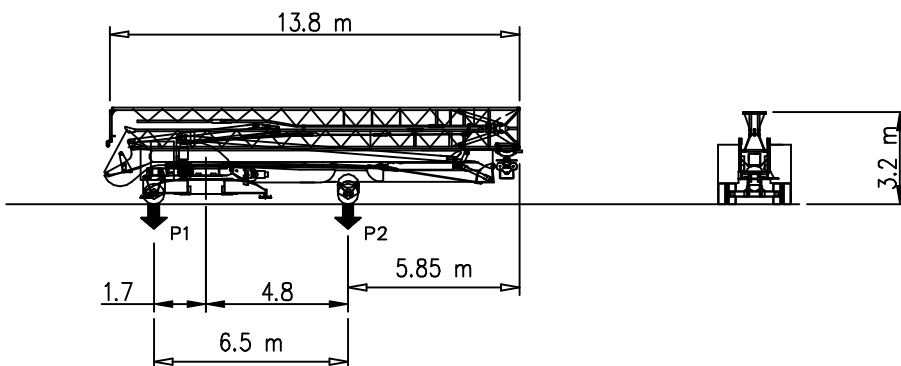



Trasporto – Transport – Transport – Transport – Transporte



P1	Kg	9260
P2	Kg	9840
Ptot	Kg	19140

Meccanismi – Mechanisms – Mécanismes – Antriebe – Mecanismos

Sollevamento V12.40 Hoisting Elevaciòn	▲ ● ▼		1a	4 m/min	2000 kg	9 kW
			2a	20 m/min	2000 kg	
			3a	40 m/min	1100 kg	
			1a	2 m/min	4000 kg	
			2a	10 m/min	4000 kg	
			3a	20 m/min	2000 kg	
Sollevamento V15.45 Hoisting Elevaciòn			1a	4 m/min	2500 kg	11 kW
			2a	15 m/min	2500 kg	
			3a	25 m/min	2000 kg	
			4a	45 m/min	1100 kg	
Carrello Trolleying Distribuciòn			1a	5 m/min	4000 kg	2.2 kW / 3 kW
			2a	17 m/min	4000 kg	
			3a	34 m/min	2000 kg	
Carrello Trolleying Distribuciòn	◀■▶		1a	5 m/min	800 kg	2.2 kW
			2a	17 m/min	800 kg	
Carrello Trolleying Distribuciòn			1a	5 m/min	1000 kg	3 kW
			2a	17 m/min	1000 kg	
Rotazione Slewing Orientaciòn			1a	0 → 0.2	giri/min tr/min rp/min	2.2 kW
			2a	0 → 0.5		
			3a	0 → 0.8		

Rete elettrica – Réseau – Mains supply – Netzstrom – Red	400V – 50 Hz
Potenza elettrica necessaria – Puissance électrique nécessaire Necessary electric power – Anschlusswert – Potencia electrica necesaria	V12.40 18 kVA V15.45 20 kVA
Conforme alla direttiva 2000/14/CE sul livello acustico Conforme à la directive 2000/14/CE sur le niveau acoustique In compliance with the 2000/14/CE instruction on noise level Germäss EWG-Richtlinie 2000/14/CE über Schall-Leistungspegel Conforme con la directiva 2000/14/CE sobre el nivel acustico	DIN 15018

AFM Gru FMgru s.r.l.
via Emilia 11-29010 Pontenure PC ITALY
tel. 0523/510446 ric.aut. fax 0523/510365
www.fmgru.com e-mail: info@fmgru.com



Documento commerciale non contrattuale
Per tutte le informazioni tecniche riferirsi
alle corrispondenti istruzioni

Unverbindliches Vertriebsdokument.
Für technische Informationen, siehe die
entsprechenden Anweisungen.

This commercial document is not legally
binding. For any technical information, please
refer to the corresponding instructions.

Documento commercial no contractual
Para cualquier información técnica,
ver la noticia correspondiente.

Code: 15ICA37B61AD			
Ed.	Data	Rev	Data
1	24.07.06	1	24.07.06